

1/4X4 H.R. FALT 9" LNG.
1 REOD.

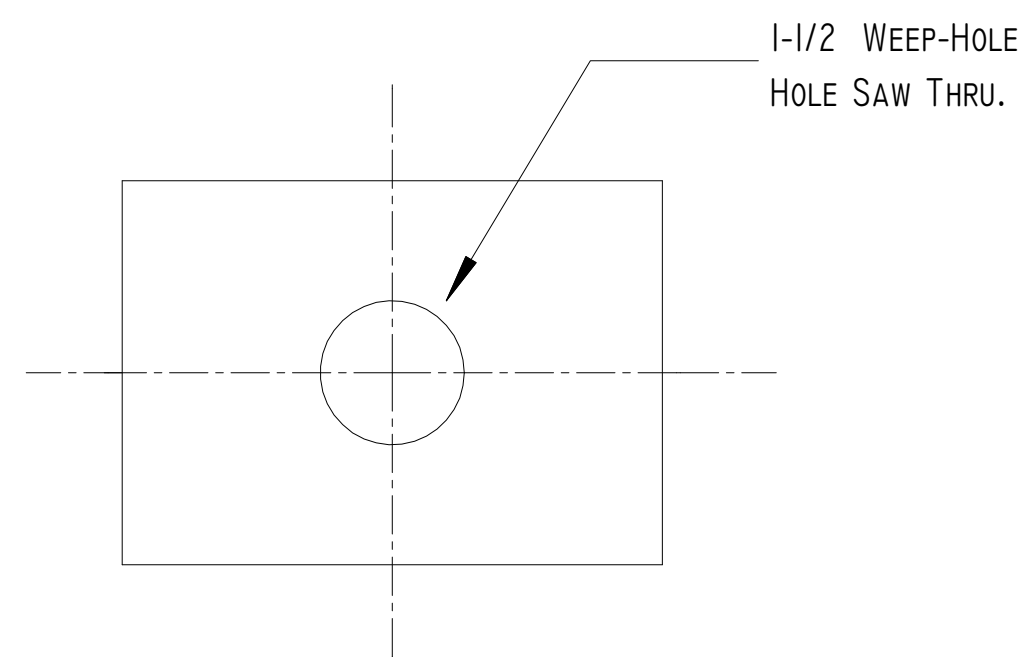

1/4X4 H.R. FALT 5-5/8" LNG.
1 REOD.

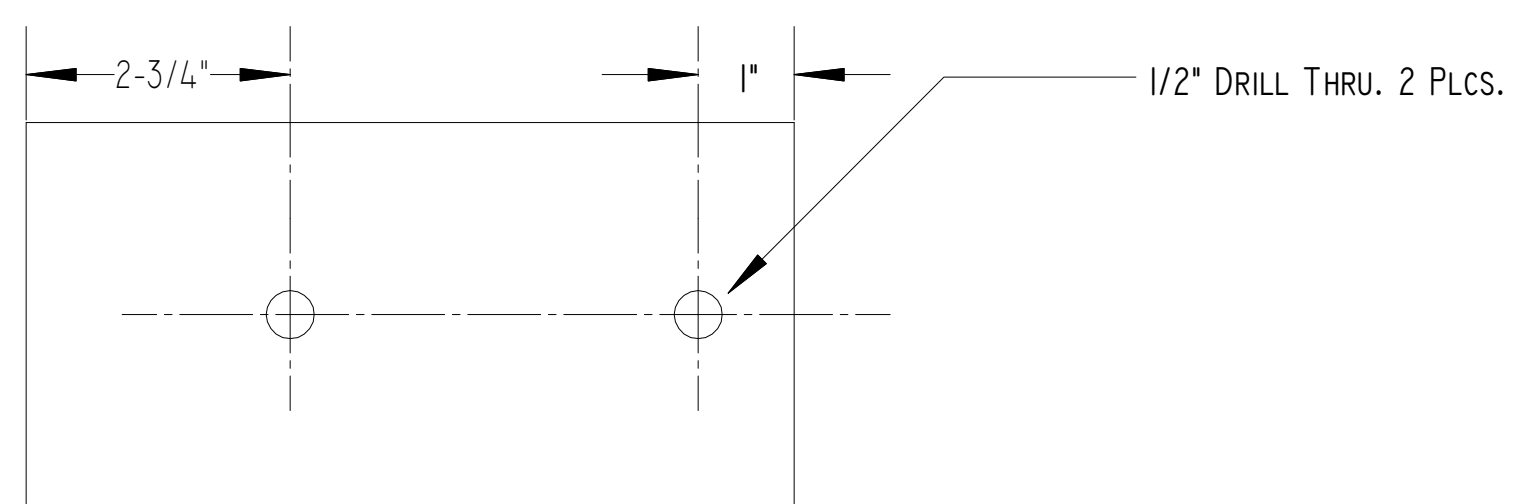

1/4X4 H.R. FALT 8" LNG.
2 REOD.

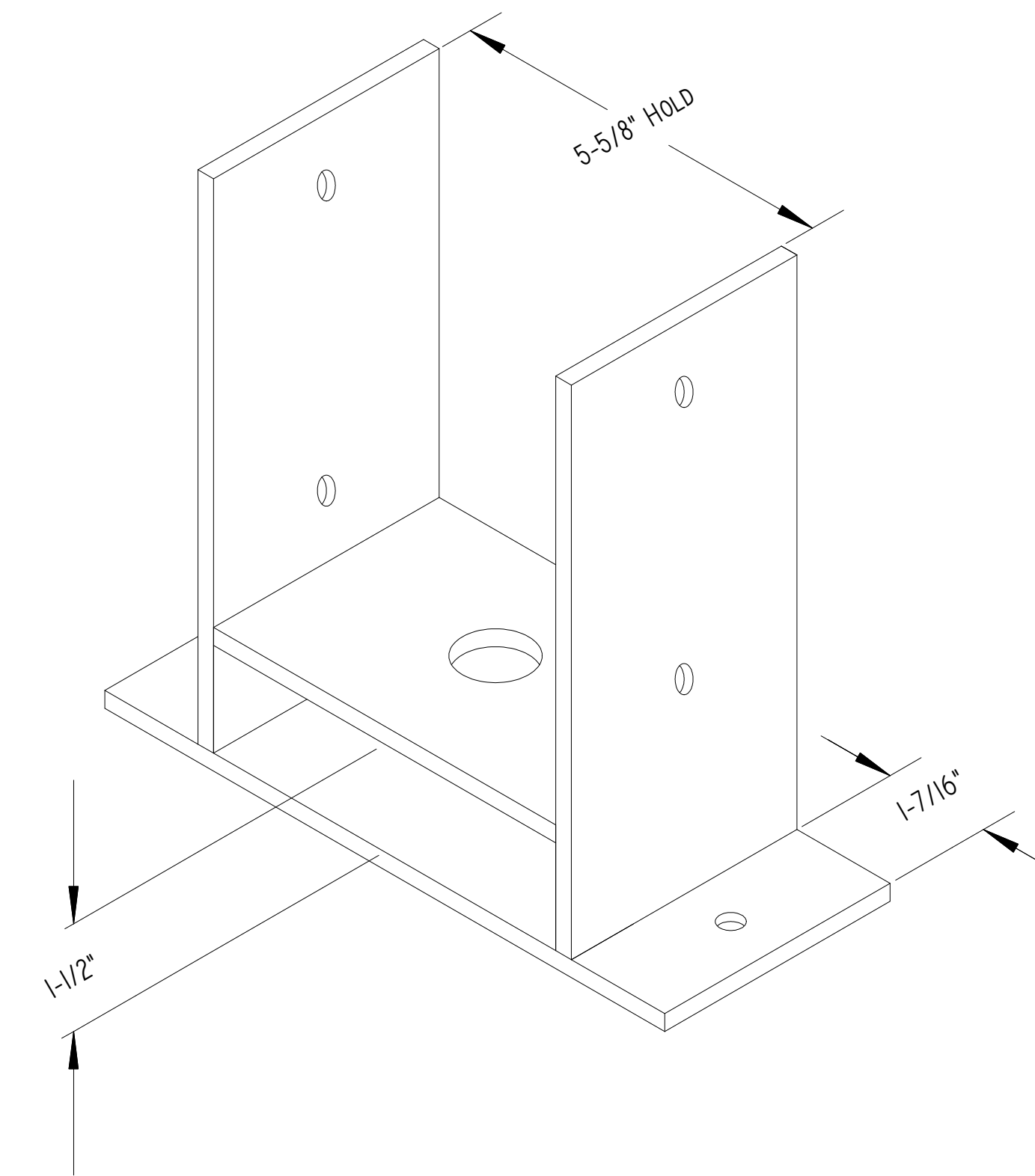

WELDMNT ASSY.
CONTINUOUS WELD E7018

4X6 STAND OFF WELDMNT

GENERAL NOTES:

DEBURR ALL SHARP EDGES
SHOP PRIME

MATERIAL:

1/4X4 H.R. FLAT A-36 ALL

PROJECT:

4X6 STAND OFF WELDMNT

Lee Design Works
DESIGNERS AND FABRICATORS

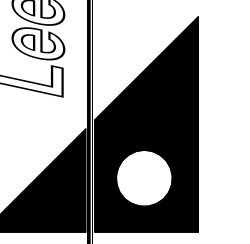

leedesignworks.com

DATE: 10-13-10

DRAWN BY: W.LEE

DRAWING No.:

SCALE UNLESS NOTED: 1/2" = 1"

SHEET:

SHOP DRAWING
1 OF 1